

LF18X451

WOOFER

DESCRIPTION

Incredibly linear frequency response characteristics, the highest power handling of any comparable 18-inch transducer, the lowest power compression.

The LF18X451 features a fibre loaded cone assembly along with a high excursion triple roll, constant geometry surround: this combination provides remarkable strength and a peak to peak maximum excursion of 54 mm. The new dual forced hyper-venting system guarantee a very efficient voice coil ventilation for minimum power compression and incredible power handling. A double silicon spider system ensures excellent control during large excursions. A fully optimised T-pole design generate the minimum amount of flux modulation.



FEATURES

- 4,5 - inch fibreglas Inside/Outside copper voice coil
- 3600 Watt continuous program power handling
- 97 dB Sensitivity
- 30 Hz - 1 kHz Frequency range
- Dual Forced Hyperventing System
- Dual spider designed with silicon based damping control
- BL of 30.5 Txm to provide a faster and accurate low frequency

TECHNICAL SPECIFICATIONS

General specifications

Nominal Diameter:	18 inch / 457 mm
Rated Impedance:	8 ohm
Program Power (watt):	3600 W
Power handling capacity:	1800 W
Sensitivity:	97.0 dB
Frequency range:	30 - 1000 Hz
Effective piston diameter:	395 mm / 15.55 inch
Max. Excursion Before Damage:	54 mm / 2.13 inch
Minimum Impedance (ohm):	6.8 ohm
Voice Coil Diameter:	4.5 inch / 114 mm
Voice Coil Winding Material:	Copper
Voice Coil Length:	34 mm / 1.34 inch
Number of layers:	2
Kind of layers:	inside/outside
Top Plate Thickness:	15 mm / 0.59 inch
Cone Design:	Straight
Surround Material:	Polycotton
Surround Design:	Triple roll
Magnets:	Ceramic
Dual-force air ventilation:	Yes
Spider:	Dual with silicon based damping control

Thiele - small parameters

Resonance frequency (Fs):	30 Hz
DC resistance (Re) (ohm):	5.40 ohm
Mechanical factor:	6.70 Qms
Electrical factor:	0.29 Qes
Total factor:	0.28 Qts
Bl factor (Bl) (T x m):	30.50 T x m
Effective moving mass (Mms):	260.0 g
Equivalent Cas air loaded (Vas):	220.0 liters
Effective piston area (Sd):	0.120 m ²
Max. linear excursion (Xmax):	14 mm
Voice coil inductance @ 1kHz (Le1k):	1.38 mH
Half-space efficiency (Eff):	1.90%

Mounting informations

Overall diameter:	465 mm / 18.31 inches
Bolt circle diameter:	442-447 mm / 17.4-17.6 inch
Bolt hole diameter:	7 mm / 0.28 inch
Front mount baffle cut-out:	424 mm / 16.69 inch
Rear mount baffle cut-out:	424 mm / 16.69 inch
Volume occupied by the driver:	6.5 liters / 0.26 ft ³

Standard compliance

CE marking:	Yes
-------------	-----



Size	Height:	212 mm / 8.35 inches
	Diameter:	465 mm / 18.31 inches
	Weight:	15.2 kg / 33.51 lbs

Shipping informations	Package Height:	254 mm / 10 inches
	Package Width:	524 mm / 20.63 inches
	Package Depth:	494 mm / 19.45 inches
	Package Weight:	17 kg / 37.48 lbs

PART NUMBER

- **11100091**
LF18X451
8ohm

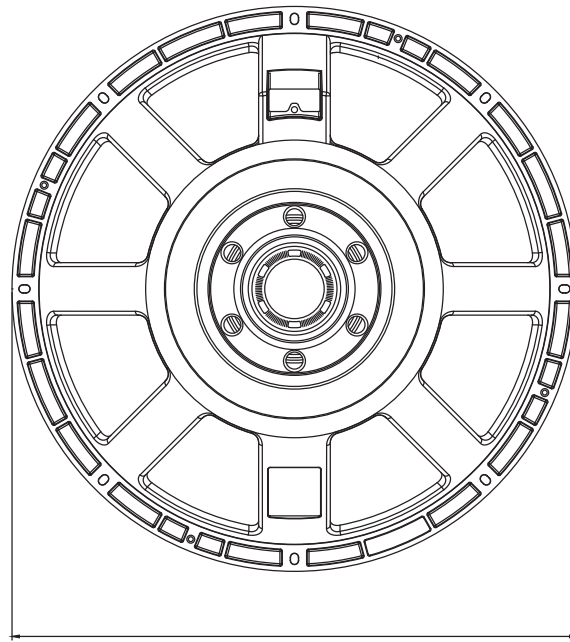

ø 465 mm

